

TIBIAL TUBEROSITY ADVANCEMENT (TTA) SYSTEM

For the treatment of
Cranial Cruciate Ligament
(CCL) disease

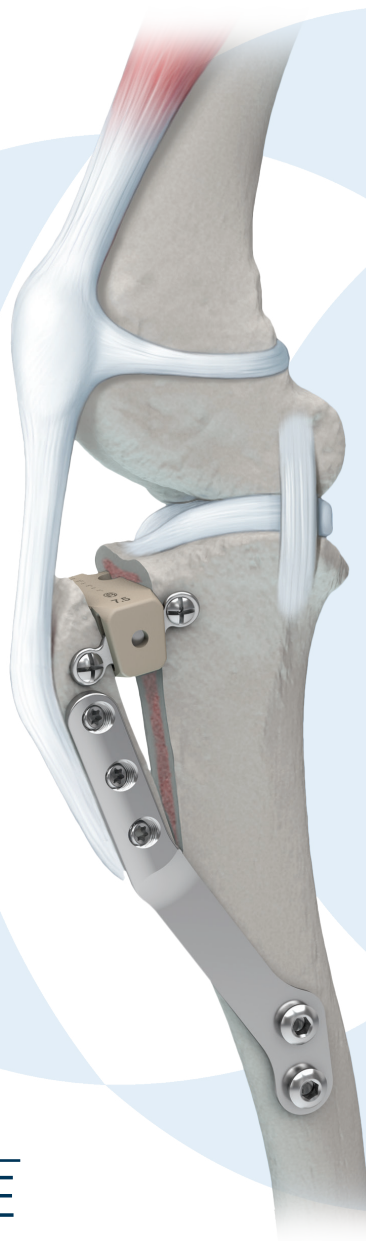

SURGICAL TECHNIQUE

TABLE OF CONTENTS

INTRODUCTION	Tibial Tuberosity Advancement (TTA) System	2
	AO Principles	4
	Indications	4

SURGICAL TECHNIQUE	Drill Guide Technique	5
	• Performing The Osteotomy	5
	• Plate Contouring and Positioning	6
	Screw/Wedge Technique	7

PRODUCT INFORMATION	Implants	14
	Instruments	18
	Set Information	22

TIBIAL TUBEROSITY ADVANCEMENT (TTA) SYSTEM

For the treatment of Cranial Cruciate Ligament (CCL) disease

The DePuy Synthes Vet Tibial Tuberosity Advancement (TTA) System is part of a stainless steel plate and screw system that merges locking screw technology with conventional plating techniques. The technical innovation of locking screws provide the ability to create a fixed-angle construct while following standard AO plating principles.

Features:

- Available in right and left versions
- Uses locking screws
- Screw trajectory is designed to enable screw purchase
- PEEK Wedge can be cut to length
- Compatible with Small and Mini Fragment Systems

TTA PLATE DESIGN

Screw holes

Proximally, the locking holes accept 2.4 mm or 2.7 mm locking screws. Distally, the round holes accept 2.7 mm or 3.5 mm cortex screws.

Fixed angle stability

The threads on the head of the locking screws lock into the threaded plate holes to form a fixed-angle construct that will increase load transfer between the plate and bone.



WEDGE DESIGN

Screw holes

The round holes accept 2.4 mm cortex screws.

Treatment for Medial Patellar Luxation

A 3 mm or 5 mm offset spacer may be attached to the round holes to allow treatment for MPL.

Cut to length

The PEEK material allows the wedge to be cut to the desired length with wire cutters. The wedge has graduated markings to show length.

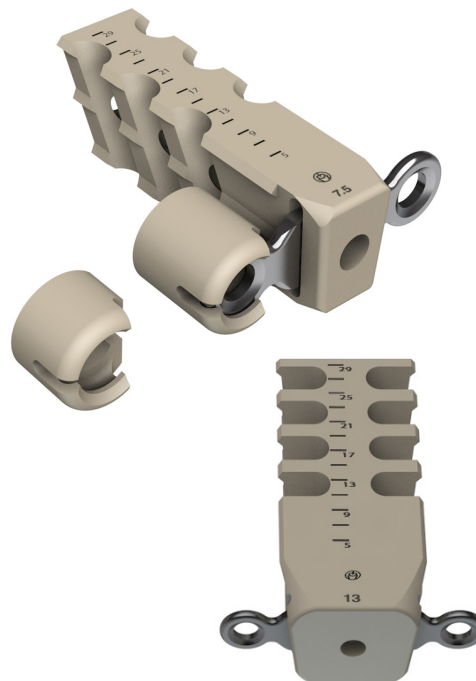

LOCKING SCREWS

Screwhead

The tapered, double-lead machine thread on the head of the locking screw engages the threads of the locking plate holes. The resulting fixed-angle construct provides stable fixation of the bone fragments without having to compress the plate to the bone. A perfectly contoured plate is therefore not required to achieve fixation and maintain proper alignment.

Thread profile

Because locking screws do not compress the plate to the bone, the “pull-out” mode of failure is not applicable to locking screws. For this reason, locking screws are made with a smaller thread profile and a larger core diameter. This results in increased mechanical strength over comparably sized cortex screws.*

Drive mechanism

The STARDRIVE™ Recess of a locking screw provides three significant improvements over an internal hex drive:

- “Stripping” of the screw head is minimized as a failure mode, which results in a much higher tolerance to wear for the screwdriver.*
- The tapered STARDRIVE Recess provides automatic screw retention without the need for an additional screw holding mechanism.
- The more efficient STARDRIVE Recess allows a smaller screw head and allows the screw head to sit flush with the plate.

Caution:

DePuy Synthes Companies of Johnson & Johnson implants and instruments are manufactured with proprietary processes that produce superior products to those created by conventional manufacturing processes. Though other companies may be able to estimate the DePuy Synthes Companies general product design, DePuy Synthes Companies product dimensions are proprietary. The precision design of DePuy Synthes Companies products is very important for long-term product function and optimal fit between implants.

Only the finest quality materials are used to manufacture DePuy Synthes Companies implants. The metals DePuy Synthes Companies uses have been scientifically proven to be of the best biocompatibility and quality available today.

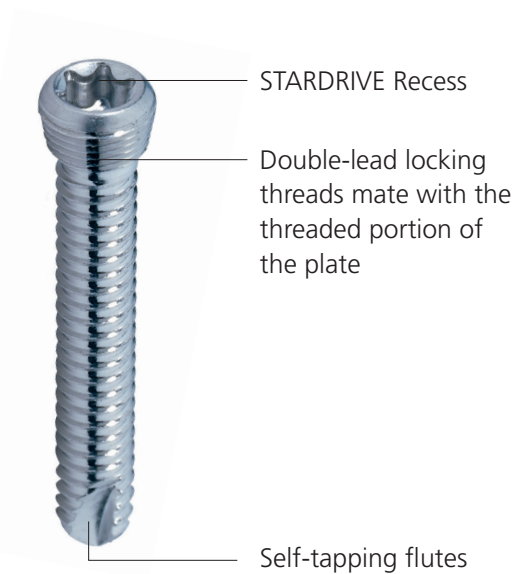

With these features and qualities, the mixing of DePuy Synthes Companies implants with the implants from other companies is not recommended. The overall performance may be compromised due to differences in design, chemical composition, mechanical properties, and quality.

Given these qualities are trade-secret, no competitor of DePuy Synthes Companies can make a genuine claim “the same as DePuy Synthes Companies.” Combining implants from other companies with DePuy Synthes Companies implants could reduce product performance. Consequently, it is strongly recommended to not mix parts from different manufacturers.

*DePuy Synthes Stardrive vs. HEX Static Torsion Test. 15 July 2013. Windchill Document #0000318278.

AO PRINCIPLES

In 1958, the AO formulated four basic principles, which have become the guidelines for internal fixation.^{1,2}
They are:

Anatomic reduction

Fracture reduction and fixation to restore anatomical relationships.

Stable fixation

Stability by fixation or splintage, as the personality of the fracture and the injury requires.

Preservation of blood supply

Preservation of the blood supply to soft tissue and bone by careful handling.

Early, safe mobilization

Early, safe mobilization of the part and patient.

INDICATIONS

The DePuy Synthes Vet TTA plate is intended for treatment of Cranial Cruciate Ligament (CCL) disease.

1. Müller ME, Allgöwer M, Schneider R, Willenegger H. *Manual of Internal Fixation: Techniques Recommended by the AO-ASIF Group*. 3rd ed. Secaucus, NJ: Springer-Verlag; 1991.
2. Rüedi TP, RE Buckley, CG Moran. *AO Principles of Fracture Management*. 2nd ed. Stuttgart, New York: Thieme. 2007.

DRILL GUIDE TECHNIQUE

Threaded drill guide

Instruments

03.111.011	1.8 mm Threaded Drill Guide, for 2.4 mm locking screws
313.353	2.0 mm Threaded Drill Guide, for 2.7 mm locking screws



03.111.011



313.353

When a locking screw is placed, a threaded drill guide must be used for guiding the drill bit in the proper direction.

Note: The threaded drill guide can also be used intraoperatively as a reference for visualizing the angle at which the locking screws will be directed into the bone.

PERFORMING THE OSTEOTOMY

1

Perform osteotomy

Instruments

532.010	Small Battery Drive
532.021	Sagittal Saw Attachment
532.065	Saw Blade, 14 mm width, 50 mm length

Create an incomplete osteotomy of the tibial tuberosity based on the preoperative plan. The osteotomy is completed in the distal one half to two thirds of the tuberosity, and only through the medial cortex in the proximal one third to one half of the tuberosity.



PLATE CONTOURING AND POSITIONING

2

Secure plate

Instruments

03.111.011	1.8 mm Threaded Drill Guide, for 2.4 mm locking screws
319.006	Depth Gauge, for 2.0 mm and 2.4 mm screws
310.510	1.8 mm Drill Bit with Quick Coupling
329.01	Bending Iron, 2 ea.

Contour the plate as needed. If treating MPL, ensure contour is appropriate.

Place the plate on the tibial tuberosity according to the pre-op plan. The cranial edge of the plate should lie within 1 mm–2 mm of the cranial aspect of the tuberosity, with the most proximal hole near to the insertion of the patellar tendon. The plate should lie on the rostral aspect of the medial side of the tuberosity.

Caution: Once the plate is in its final position, the proximal round hole in the distal aspect of the plate should be no closer than 10 mm to the osteotomy. If the distance is less than 10 mm, consider using a larger plate.

The plate can be clamped into position if desired.

Note: A threaded drill guide inserted into one of the proximal plate holes can be used to hold the plate during placement and clamping.



SCREW/WEDGE TECHNIQUE

Refer to the DePuy Synthes Vet Small Fragment Technique Guide for correct screw insertion techniques.

Note: All screws must be fully tightened for proper function. Avoid overtightening cortex screws as this may result in stripping the bone. Do not lock the screws to the plate under power. It is recommended that screw head thread engagement and final locking torque should be performed manually.

For 2.4 mm and 2.7 mm Locking Screws, 511.776 Torque Limiting Attachment, 0.8 Nm, quick coupling can be used. Screws inserted with the torque limiting adapter should be checked by hand to ensure they are fully tightened.

3

Screw insertion order

The following technique is shown using the 2.4 mm/3.5 mm TTA plate. It is recommended that screws be inserted in the sequence described below:

3a

Insert threaded drill guide into hole 1. Insert a 2.4 mm locking screw using standard locking screw insertion technique.

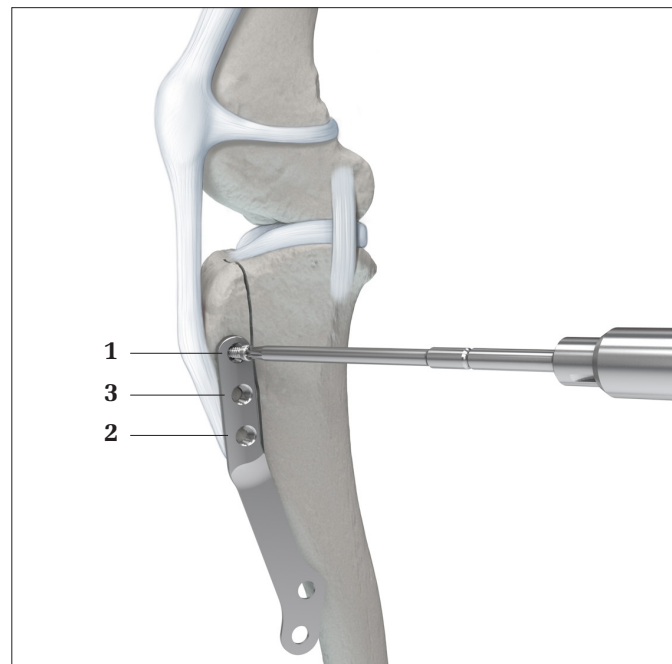

3b

Check the size and placement of the plate to ensure hole 2 is positioned to permit good bone purchase and the distal end of the plate is sufficiently forward, based on the pre-op plan (see Step 2).

At this point, the plate may be substituted for a larger or smaller size by removing screw 1.

If desired, the plate can be adjusted by loosening screw 1 slightly, rotating the plate, and then retightening.

If the plate placement is satisfactory, insert a 2.4 mm locking screw into hole 2.

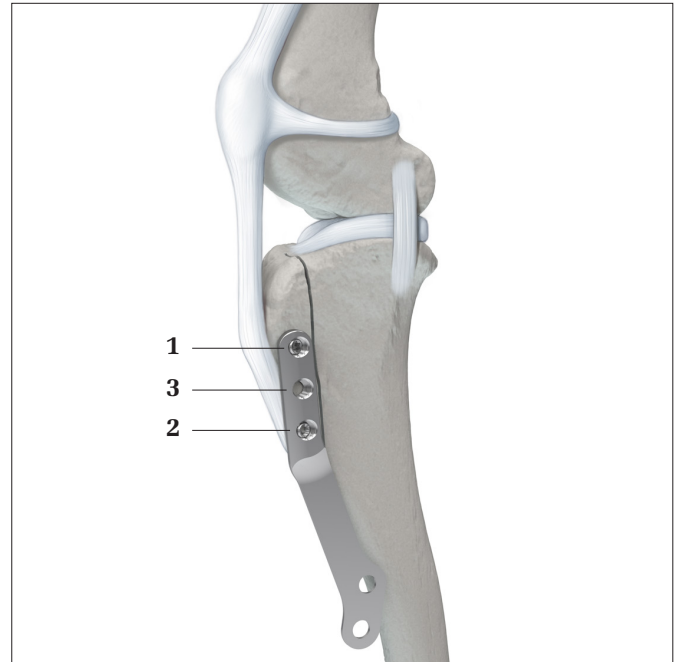

3c

Insert a 2.4 mm locking screw into hole 3.

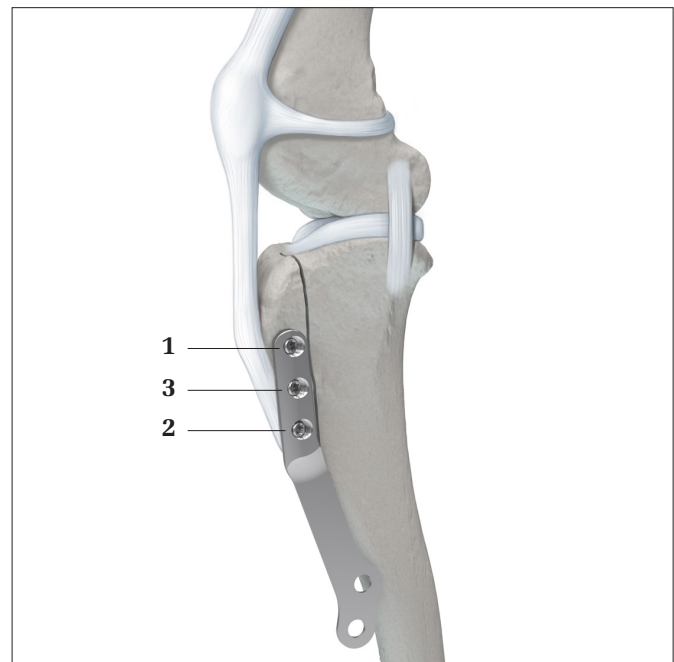

4

Instruments

532.010	Small Battery Drive
532.021	Sagittal Saw Attachment
532.065	Saw Blade, 14 mm width, 50 mm length

Complete the osteotomy through the proximal cortex.



5

Instruments

VQ5001.06– VQ5001.15	Osteotomy Spreader
311.44	T-Handle, QC

Open osteotomy.

Release the lateral tissue with scissors.

Insert osteotomy spreader and rotate it in order to open the osteotomy to allow insertion of the selected wedge.

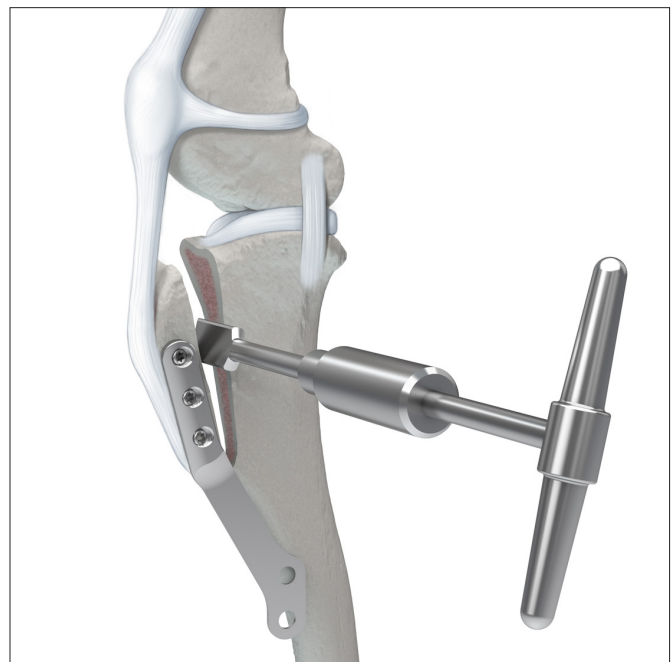

6

Instruments

319.006	Depth Gauge, for 2.0 mm and 2.4 mm screws
---------	---

391.94	Small Wire Cutter
--------	-------------------

Measure the width of the tuberosity with the depth gauge and cut the wedge to the appropriate length. The proximal face of the wedge is graduated to facilitate this step.



7

Instrument

329.12	Bending Pliers
--------	----------------

Contour tabs on wedge plate to match the slope of the medial bone cortex at the osteotomy:

For a left tibia (**Figure shown**), the caudal tab is rotated clockwise and bent up, while the cranial tab is rotated counterclockwise and bent down. Failure to match the contour of the bone will result in tipping of the cage.

For a right tibia, the caudal tab is rotated counterclockwise and bent up while the cranial tab is rotated clockwise and bent down to follow the contour of the bone surface.

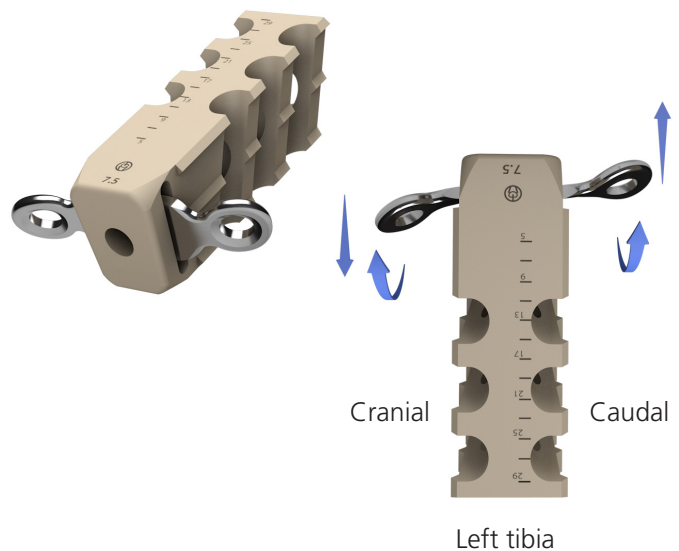

8

Insert wedge

Cancellous bone graft is recommended to be placed into the gap and within the wedge. Graft cannot be placed into the wedge after implantation, so graft must be placed into the wedge prior to insertion into the osteotomy.



8a

If treating MPL, add appropriate spacer to wedge and insert wedge to simultaneously transpose the tibial tuberosity laterally.

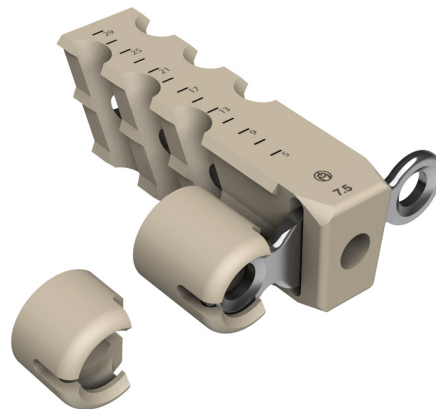

9

Instruments for 2.4 mm screws

319.006	Depth Gauge, for 2.0 mm and 2.4 mm screws
323.202	2.4 mm Universal Drill Guide
313.94.96	2.4 mm Cruciform Screwdriver
310.510	1.8 mm Drill Bit with Quick Coupling

Insert 2.4 mm cortex screw into hole 4. The screw should be oriented caudadistal.

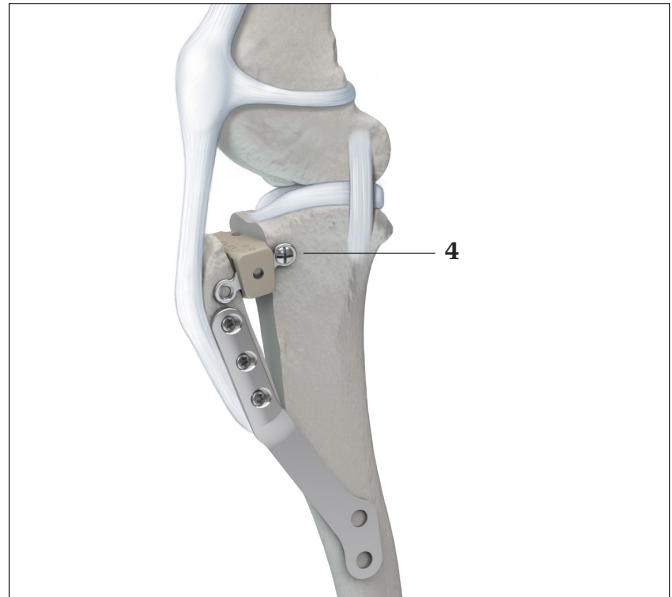

10

Instruments for 3.5 mm screws

319.01	Depth Gauge, for 2.7 mm, 3.5 mm, and 4.0 mm Screws
310.25	2.5 mm Drill Bit with Quick Coupling
323.36	3.5 mm Universal Drill Guide
314.02	Small Hex Screwdriver

Using pointed reduction forceps, compress distal end of the tibial tuberosity to the tibial shaft to ensure bone contact at this level. Ideally, the distal plate holes should sit in the center of the tibial diaphysis. Additional distal plate contouring (in the segment between the plate holes) may be required if the hole position is located further caudal after advancing the tuberosity; the tibial shaft must be in contact with the plate.

Insert 3.5 mm cortex screw in the most proximal round hole of the distal end of the plate.

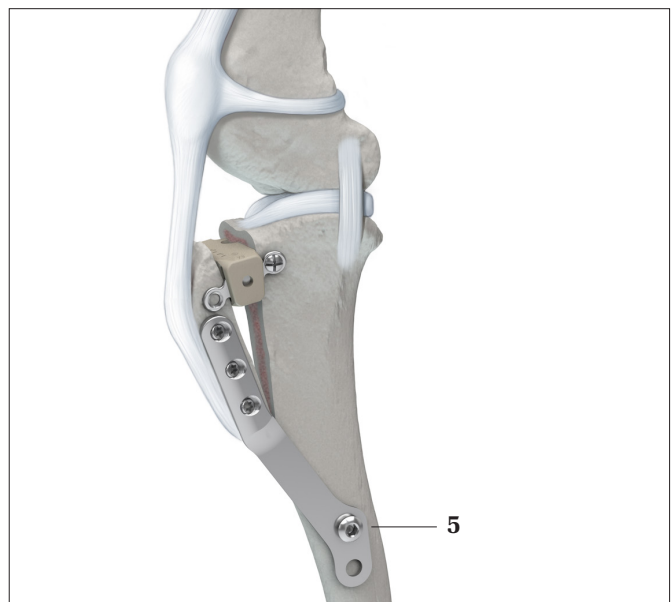

Caution: Once the plate is in its final position, the proximal round hole in the distal aspect of the plate should be no closer than 10 mm to the osteotomy. If the distance is less than 10 mm, consider using a larger plate.

11

Insert 2.4 mm cortex screw in the second wedge screw in hole 6. The screw should be oriented cranioproximal with no protruding tip/threads laterally.

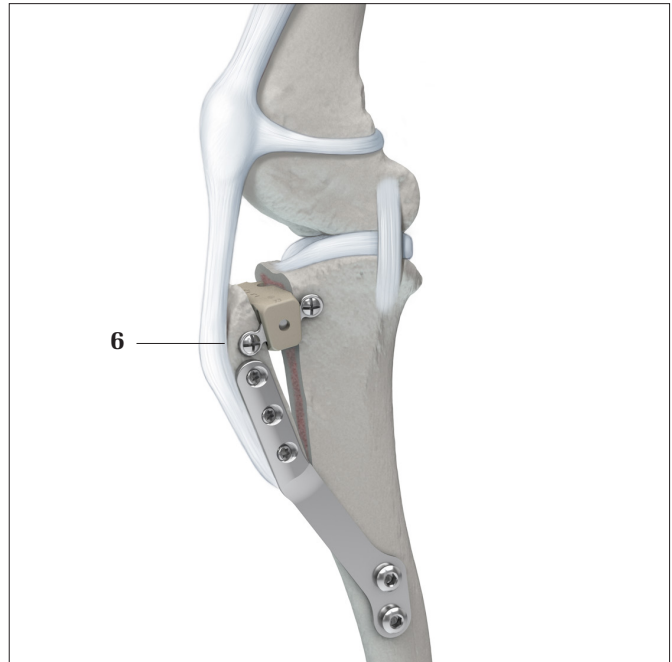

12

Insert 3.5 mm cortex screw in hole 7.

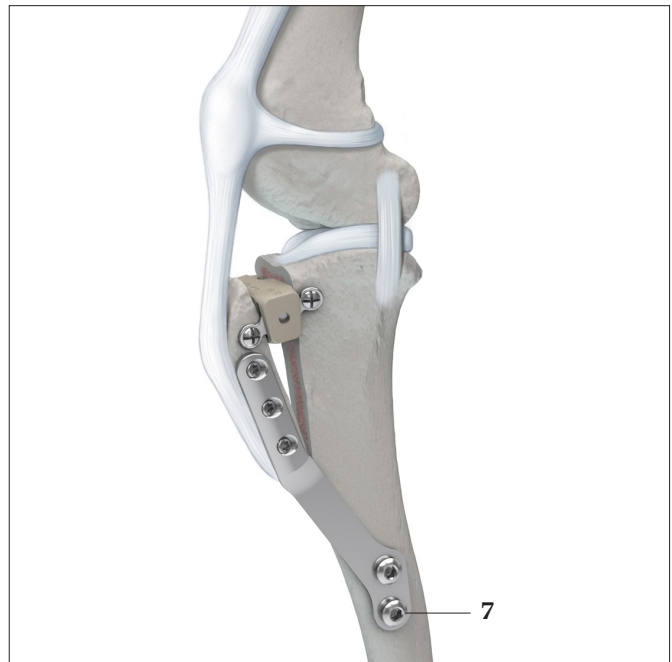

IMPLANTS

2.4 mm Locking Screws, self-tapping, with STARDRIVE Recess

VS208.006– 6 mm–14 mm (in 1 mm increments)
 VS208.014
 VS208.016– 16 mm–30 mm (in 2 mm increments)
 VS208.030

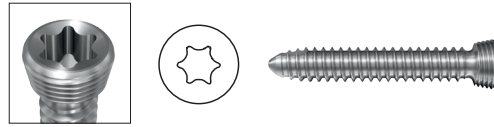

2.4 mm Cortex Screws, self-tapping, with hexagonal recess

VS203.006– 6 mm–14 mm (in 1 mm increments)
 VS203.014
 VS203.016– 16 mm–40 mm (in 2 mm increments)
 VS203.040

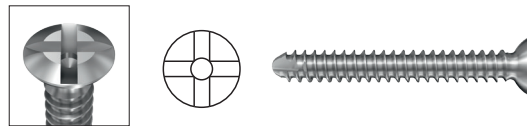

2.7 mm Locking Screws, self-tapping, with STARDRIVE Recess

VS206.010– 10 mm–34 mm (in 2 mm increments)
 VS206.034

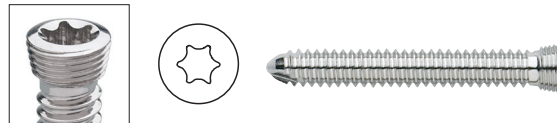

2.7 mm Cortex Screws, self-tapping, with hexagonal recess

VS205.010– 10 mm–50 mm (in 2 mm increments)
 VS205.050
 VS205.055– 55 mm–70 mm (in 5 mm increments)
 VS205.070

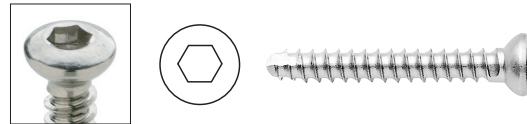

3.5 mm Cortex Screws, self-tapping, with hexagonal recess

VS302.0106– 10 mm–50 mm (in 2 mm increments)
 VS302.050
 VS302.0556– 55 mm–70 mm (in 5 mm increments)
 VS302.070



Thread Diameter	2.4 mm	2.4 mm	2.7 mm	2.7 mm	3.5 mm
Screw Type	Cortex	Locking	Cortex	Locking	Cortex
Drill Bit for Threaded Hole	1.8 mm	1.8 mm	2.0 mm	2.0 mm	2.5 mm
Tap	Self-Tapping	Self-Tapping	2.7 mm	Self-Tapping	3.5 mm
Drive Type	2.4 mm Cruciform	T8 STARDRIVE	2.5 mm Hexagonal	T8 STARDRIVE	2.5 mm Hexagonal

Also Available

2.7 mm Cortex Screws, non-self-tapping, with hexagonal recess

VS204.006– 10 mm–50 mm (in 2 mm increments)

VS204.040

VS204.045– 40 mm–55 mm (in 5 mm increments)

VS204.055



3.5 mm Cortex Screws, non-self-tapping

VS301.010– 10 mm–50 mm (in 2 mm increments)

VS301.040

VS301.045– 45 mm–70 mm (in 5 mm increments)

VS301.070



2.4 mm/2.7 mm TTA Plates

- VP5031.L4 Left, 53 mm
- VP5031.R4 Right, 53 mm
- VP5031.L5 Left, 65 mm
- VP5031.R5 Right, 65 mm

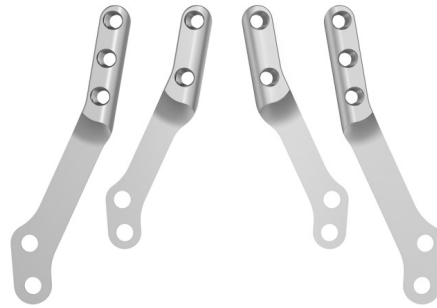

2.4 mm/3.5 mm TTA Plates

- VP5041.L6 Left, 78 mm
- VP5041.R6 Right, 78 mm
- VP5041.L7 Left, 90 mm
- VP5041.R7 Right, 90 mm
- VP5041.L8 Left, 104 mm
- VP5041.R8 Right, 104 mm

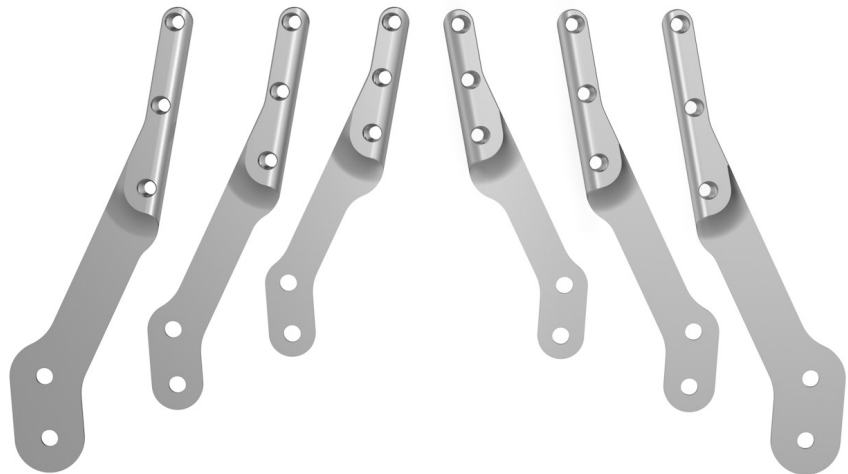

Wedges

VP5052.04	4.5 mm, 19 mm long
VP5052.06	6.0 mm, 22 mm long
VP5052.07	7.5 mm, 22 mm long
VP5052.09	9.0 mm, 25 mm long
VP5052.10	10.5 mm, 25 mm long
VP5052.12	12.0 mm, 28 mm long
VP5052.13	13.5 mm, 31 mm long
VP5052.15	15.0 mm, 31 mm long

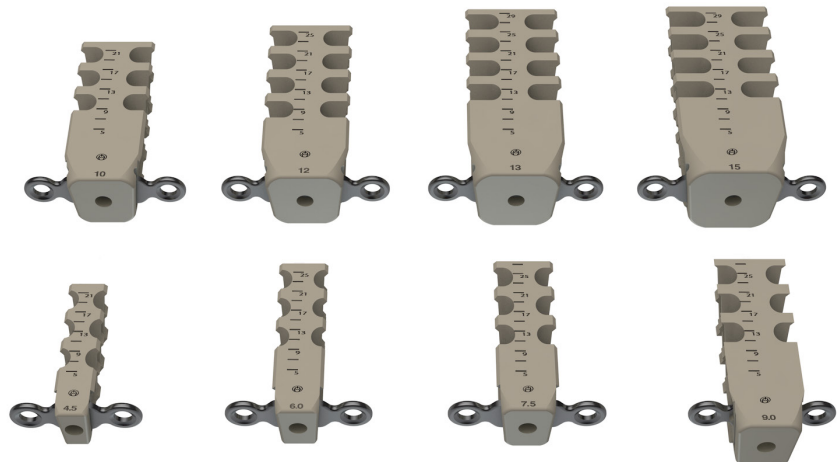

Spacers

VP5053.03	3 mm Offset
VP5053.05	5 mm Offset

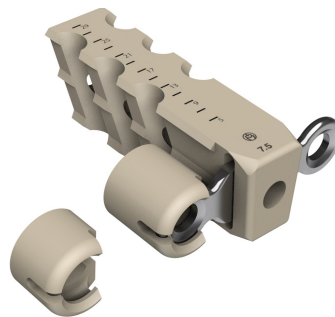

INSTRUMENTS

TTA OSTEOTOMY SPREADER

VQ5001.06 6 mm Blade



VQ5001.09 9 mm Blade



VQ5001.12 12 mm Blade



VQ5001.15 15 mm Blade



311.44 T-Handle, QC

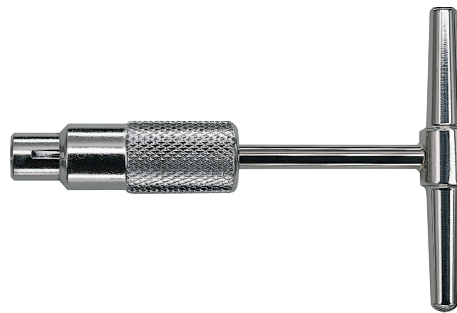

BENDING/CUTTING

329.01 Bending Iron, 2 ea

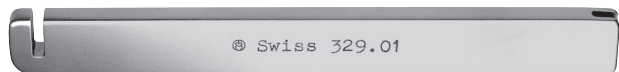

329.12 Bending Pliers



391.94 Small Wire Cutter

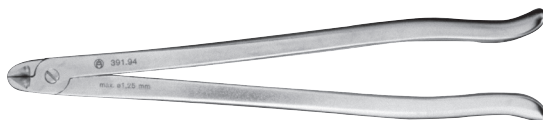

SMALL FRAGMENT AND MINI FRAGMENT INSTRUMENTS

FOR 2.4 MM CORTEX SCREW

313.94.96 Cruciform Screwdriver



310.510 1.8 mm Drill Bit, quick coupling, 100 mm



319.006 Depth Gauge, for 2.0 mm and 2.4 mm screws



323.202 2.4 mm Universal Drill Guide



FOR 2.4 MM LOCKING SCREW

03.111.011 1.8 mm Threaded Drill Guide



310.510 1.8 mm Drill Bit, quick coupling, 100 mm



311.43 Handle with Quick Coupling



314.467 STARDRIVE Screwdriver Shaft, T8, quick coupling



319.006 Depth Gauge, for 2.0 mm and 2.4 mm screws



FOR 2.7 MM CORTEX SCREW

310.21 2.0 mm Drill Bit, quick coupling, 125 mm



314.02 Small Hexagonal Screwdriver with Holding Sleeve



319.01 Depth Gauge, for 2.7 mm, 3.5 mm, and 4.0 mm Screws



323.26 2.7 mm Universal Drill Guide



FOR 2.7 MM LOCKING SCREW

310.21 2.0 mm Drill Bit, quick coupling, 125 mm



311.43 Handle with Quick Coupling



313.353 2.0 mm Threaded Drill Guide



314.467 STARDRIVE Screwdriver Shaft, T8, quick coupling



319.01 Depth Gauge, for 2.7 mm, 3.5 mm, and 4.0 mm Screws



FOR 3.5 MM CORTEX SCREW

310.25 2.5 mm Drill Bit, quick coupling, 110 mm



323.36 3.5 mm Universal Drill Guide



319.01 Depth Gauge, for 2.7 mm, 3.5 mm, and 4.0 mm Screws



314.02 Small Hexagonal Screwdriver with Holding Sleeve



ALSO AVAILABLE

511.776 Torque Limiting Attachment, 0.8 Nm, quick coupling
– For use with 2.4 mm and 2.7 mm locking screws



Small Battery Drive II Accessories

05.001.204 Universal Battery Charger II
05.001.250 AO/ASIF Quick Coupling for Drill Bits
532.104 Battery Insertion Shield
532.110 Small Battery Drive II
532.022 Quick Coupling for K-wires
532.132 Battery Casing for 14.4 V Li Ion Battery
532.021 Sagittal Saw Attachment
532.103 14.4 V Li Ion Battery for Small Battery Drive II
532.065 Saw Blade, 14 mm width, 50 mm length

For the full range of attachments and accessories for the Small Battery Drive II, please contact your DePuy Synthes Vet representative or consult the DePuy Synthes Power Tools product catalog.

SET INFORMATION

RECOMMENDED SETS

- 103.521 Mini Fragment Instrument Set
- 103.524 Mini Fragment Implant Set



103.521



103.524

For detailed cleaning and sterilization instructions, please refer to:
www.synthes.com/cleaning-sterilization
In Canada, the cleaning and sterilization instructions will be provided with the Loaner shipments.

Set Information

- 103.503 Small Fragment Instrument Set
- 103.515 Small Fragment Screw Set
- 690.560 TTA Set Module Case



103.503



690.560

Please refer to the instructions for use for a complete list of indications, contraindications, warnings and precautions.

AO Foundation is a 3rd party medically guided, not-for-profit organization led by an international group of surgeons specialized in the treatment of trauma and disorders of the musculoskeletal system.



PART OF THE *Johnson & Johnson* FAMILY OF COMPANIES

DePuy Synthes Vet
1302 Wrights Lane East
West Chester, PA 19380
Telephone: (610) 719-5000
To order: (800) 523-0322

Synthes GmbH
Luzernstrasse 21
4528 Zuchwil, Switzerland

Note: For recognized manufacturer, refer to the product label.

www.jjmdanimalhealth.com

© DePuy Synthes 2016, 2020, 2022. All rights reserved.
153173-220414 DSUS 04/22 DV